

Technical Data

	<p>RS 250 - Conveyor</p> <p>length: 300 - 6000 mm width: 400 mm, 500 mm inclination: 0 - 12° options: pivotable (manual or pneumatic) telescopic, divert gate function, walkway function, jogger for thick products</p>
	<p>RS 260 - Flow Turn</p> <p>width: 400 mm, 500 mm radius: 600 mm (opt. 900 mm) angles: 15°, 30°, 45°, 60°, 90°, 180° options: with infeed or delivery extension</p>
	<p>RS 220 - Multifformat Bumpturn</p> <p>formats: A5 - A3 infeed: min height 600 mm (23.62") options: straight out delivery, vacuum assisted delivery belt, side mounted control cabinet</p>
	<p>RS 230 - Multifformat Tower</p> <p>formats: A5 - A3 infeed: min height 660 mm (25.98") options: straight out delivery, vacuum assisted delivery belt, side mounted control cabinet</p>

Technical specification available on request. The manufacturer reserves the right to change the technical specifications without prior notice (RS 200-E-03/00).

RIMA SYSTEM
www.rima-system.com

RIMA-SYSTEM Atlanta LLC, USA
2840 Johnson Ferry Road, Suite 250
Marietta, GA 30062-8309
Phone +1 - 770 - 998 5622
Fax +1 - 770 - 998 5680

RIMA-SYSTEM Corporate Office, USA
5340 Argosy Drive,
Huntington Beach, CA 92649
Phone +1 - 714 - 893 4534
Fax +1 - 714 - 892 7010

RIMA-SYSTEM Europe, Germany
Postfach 27 03 49, D - 40526 Düsseldorf
Monschauer Str. 1, D - 40549 Düsseldorf
Phone +49 - 211 - 950090
Fax +49 - 211 - 9500911

RIMA-SYSTEM Far East Pte Ltd, Singapore
11 Stamford Road, # 03-10 Capitol Building
Singapore 178884
Phone +65 - 6 338 5580
Fax +65 - 6 338 5582

POST PRESS

MAIL ROOM

BOOKBINDERY

We find the right way

RS 200 - RIMA-SYSTEM Conveyor and Deviation System



RIMA SYSTEM



RS 250 - Conveyor

- Solid, height adjustable flat belt conveyor
- Integrated tensioning device for perfect belt guidance
- Fixed distance between axis
- Optional infeed or delivery extensions driven by the main conveyor
- Telescopie

RS 260 - Flow Turns

- Solid, flat belt flow turns with integrated steel support plate
- Deflector on the delivery side for safe shingled stream transport
- Drive mounted underneath the flow turn
- Optional infeed or delivery extensions driven by the flow turn

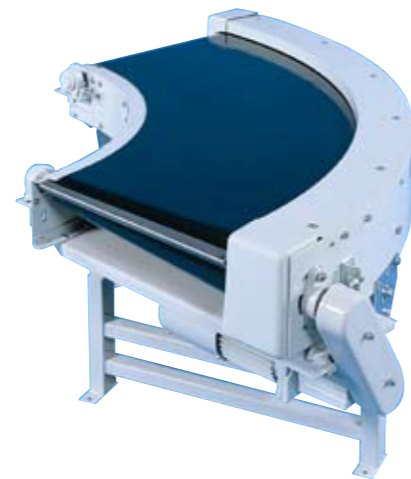

RS 250 - Deviation System

- Solid, height adjustable flat belt conveyor
- Manual or pneumatic actuation
- Switches one conveyor line between two or more conveyor lines or vice versa
- Divert gate for manual and automatic (e.g. blanket wash) waste copy ejection

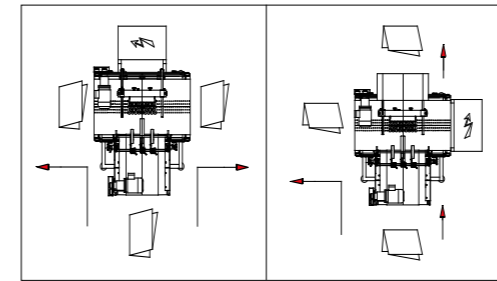
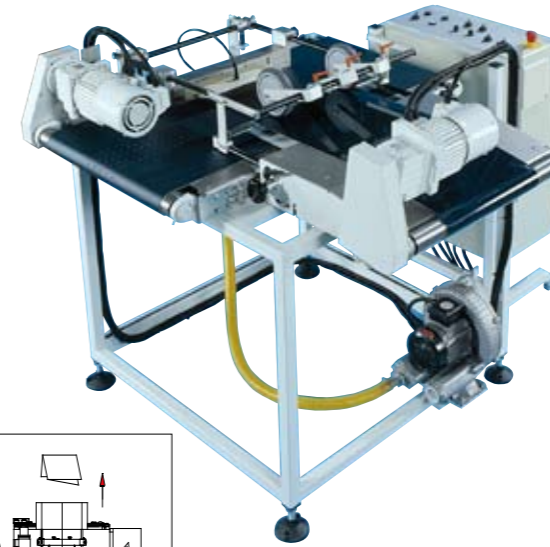

RS 220 - Multifformat Bumturn

- Telescopic infeed conveyor for centered product delivery
- Selectable left or right hand delivery
- Independent drives for infeed and delivery conveyor
- Adjustable bump plate with integral air nozzle
- Infeed conveyor with position adjustable spring loaded wheels
- Optional infeed or delivery extensions driven by the main conveyor
- Control cabinet according to UL, CSA or VDE/CE guidelines

RS 230 - Multifformat Tower

- Combination of RS 220 bumturn and RS 260 flow turn mounted in a single frame
- Manual or electrical height adjustment
- Control cabinet according to UL, CSA or VDE/CE guidelines

