

▶ POST PRESS

▶ MAIL ROOM

▶ BOOKBINDERY

# Like a brick

RS 51 - High Quality Lift Stacker for PFF-deliveries

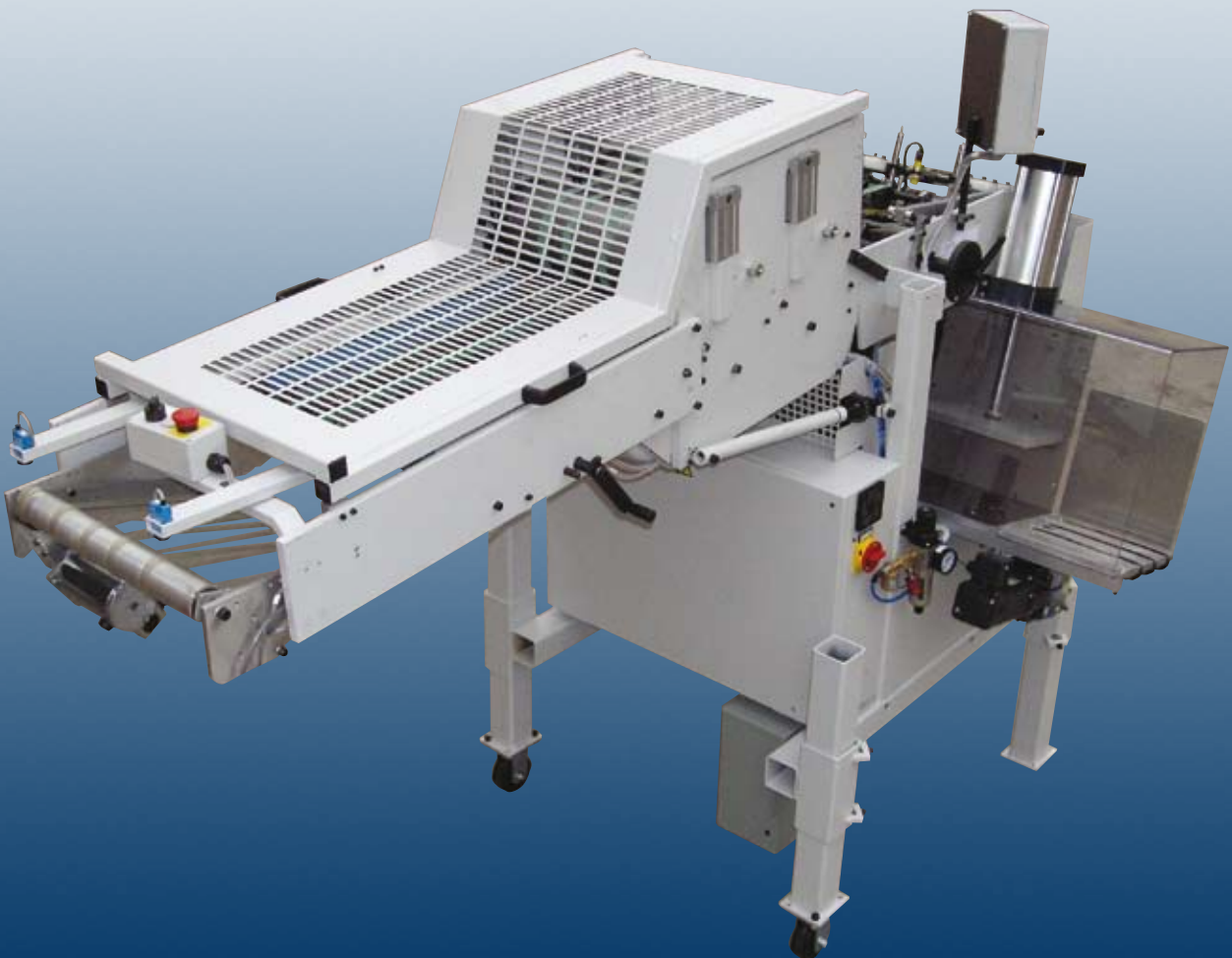

**RIMA**  **SYSTEM**

## Requirements & Solutions

The RS 51 lift stacker is the best solution for high-speed presses delivering a shingled stream of three side open products. The stacker produces compressed, brick-like stacks of excellent quality.

The non-gapping vertical stacker integrates modern servo technology and a pressing unit thus guaranteeing superior stack stability for further processing. This allows the efficient robotic palletizing of loose stacks without the need of further strapping. The durable steel infeed is equipped with an automatic divert gate and can be adjusted to different heights.

## Technical Data

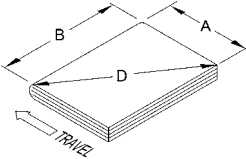
Formats		Minimum	Maximum
	"A" Dimension	152 mm (6.00")	292 mm (11.50")
	"B" Dimension	267 mm (10.50")	308 mm (12.13")
	Stack height before stack compression	200 mm (8.00")	340 mm (13.38")
Infeed height	var. between	1223 mm (48.14")	1730 mm (68.09")
Delivery height	864 mm ± 50 mm (34.00" ± 2.00")		
Operating speed	up to 100.000 products per hour or nine stacks per minute		
Input power	220/400/440 VAC, 3~, 50/60 Hz, 4 KVA		
Air requirement	170 l/min @ 5.5 bar (6 cfm @ 80 psi)		

Technical specifications available on request. The manufacturer reserves the right to change the technical specifications without prior notice (RS 51-E-07/05).

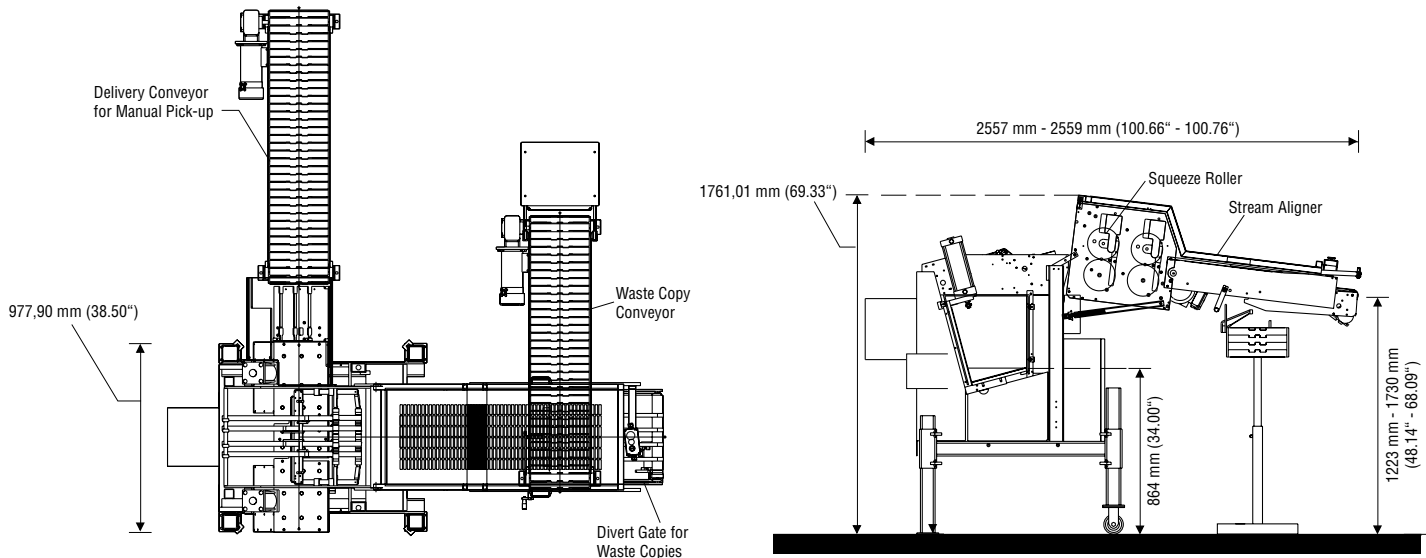

**RIMA SYSTEM**  
www.rima-system.com

RIMA-SYSTEM Atlanta LLC, USA  
2840 Johnson Ferry Road, Suite 250  
Marietta, GA 30062-8309  
Phone +1 - 770 - 998 5622  
Fax +1 - 770 - 998 5680

RIMA-SYSTEM Corporate Office, USA  
5340 Argosy Drive  
Huntington Beach, CA 92649  
Phone +1 - 714 - 893 4534  
Fax +1 - 714 - 892 7010

RIMA-SYSTEM Europe, Germany  
Postfach 27 03 49, D - 40526 Düsseldorf  
Monschauer Str. 1, D - 40549 Düsseldorf  
Phone +49 - 211 - 950090  
Fax +49 - 211 - 9500911

RIMA-SYSTEM Far East Pte Ltd, Singapore  
11 Stamford Road, # 03-10 Capitol Building  
Singapore 178884  
Phone +65 - 6 338 5580  
Fax +65 - 6 338 5582